

Application and Design

The Model FDD-110-3V is UL Classified for installation in walls, floors, and partitions with a fire rating of less than 3 hours. This damper may be installed vertically or horizontally in dynamic HVAC systems that continue to operate in the event of a fire. Also approved for static systems.

Standard Construction

Frame: 5" Roll Formed Frame - Galvanized Steel Hat-section w/ stalked corners & Integral bracing

Blades: 16 Ga. Roll formed - Galvanized steel
 min. width 4-1/4" (108mm)
 max. width 7-1/4" (184mm)

Axles: square plated steel

Linkage: Concealed in frame. Linkage bars are 1/8" (3.2mm)

Bearings: Bronze Oilite press-fit into frame

Closure Spring: Stainless Steel

Fusible Link - UL-33: UL Listed 165°F (standard), 212°F (optional)

Manual Locking Quadrant- (may be required for inspection)

Max. velocity: 2000 fpm (10.2 m/s),

(4000 fpm available on select sizes (see table))

max. pressure: 4" wg (1kPa) , (6" wg available on select sizes (see table))

Options:

- Factory Sleeve: _____ Ga (18 Ga min) Out of Wall Const. Available (see dwg. P-36 inst.)
- Sleeve Length: _____ Inches
- Retaining Angles 3 Hour Rating
- EFL (Electric Fusible Link)* Round Transitions (FDD-110-3V-CR)
- PFV (Pneumatic Fusible Valve)* 250° - 350° (Actuator Req.)
- Mounting:
 - Horizontal
 - Vertical

* Option provides quick and economical way to check damper operations and also a Systematic Closure Control. Option PFV allow damper operation without the need/cost for an EP valve and electrical connection at the damper.

+ Note: Non-sleeved (with side plate) dampers are furnished Approx. 1/4" (6.4mm) smaller than given duct dimensions. Sleeved dampers are furnished Approx. the same size as given duct dimension, unless otherwise noted.

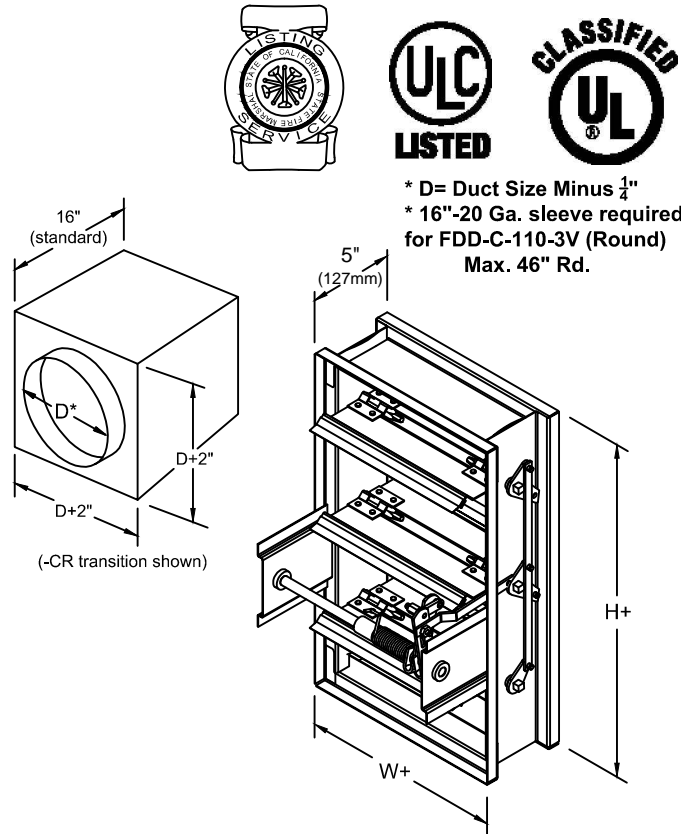

* D = Duct Size Minus 1/4"
 * 16"-20 Ga. sleeve required for FDD-C-110-3V (Round)
 Max. 46" Rd.

Model FDD-110-3V meets or complies with the following as a fire damper: All major building codes, including IBC/ICC International Code UL 555 Listing 1-1/2 and 3 hour - File #R25410, ULC S122, NFPA - 90A, 80

Standard Sizes (Duct) 1-1/2 HR.

Operator Type	Min. Width	Max Single Section	Max Rated Airflow	*Max Vertical Size(s)	*Max Horizontal Size	Max Rated Airflow	Max S.P.
Spring	6" x 6" (152mm x 152mm)	36"w x 48"h (914mm x 1219mm)	4000 FPM	72"w x 48"h (1829mm x 1219mm) 36"w x 96"h (914mm x 2438mm)	72"w x 48"h (1829mm x 1219mm)	2000 FPM	6" w.g.
Actuator	6" x 6" (152mm x 152mm)	36"w x 48"h (914mm x 1219mm)	2000 FPM	108"w x 96"h (2743mm x 2438mm)	144"w x 96"h (2743mm x 2438mm)	2000 FPM	4" w.g.

*May consist of multi-sections (Max single section size: 36"w x 48"h (914mm x 1219mm))

Standard Sizes (Duct) 3 HR.

Operator Type	Min. Width	Max Single Section	Max Rated Airflow	*Max Vertical Size(s)	*Max Horizontal Size	Max Rated Airflow	Max S.P.
Spring	6" x 6" (152mm x 152mm)	36"w x 48"h (914mm x 1219mm)	4000 FPM	72"w x 48"h (1829mm x 1219mm) 36"w x 96"h (914mm x 2438mm)	72"w x 48"h (1829mm x 1219mm)	2000 FPM	6" w.g.
Actuator	6" x 6" (152mm x 152mm)	36"w x 48"h (914mm x 1219mm)	2000 FPM	72"w x 48"h (1829mm x 1219mm)	72"w x 48"h (1829mm x 1219mm)	2000 FPM	4" w.g.

*May consist of multi-sections (Max single section size: 36"w x 48"h (914mm x 1219mm))

JOB NAME:	<input type="checkbox"/> MODEL FDD-110-3V <input type="checkbox"/> MODEL FD-110-3V-OW (Out of Wall) <input type="checkbox"/> MODEL FD-110-3V-CR (Round)		
LOCATION:			
ARCHITECT:			
ENGINEER:	DRAWN BY: GAB	DATE: 3-1-18	REV. DATE: 2-13-20
CONTRACTOR:	REV. NO. 1	APPROVED BY: CLJ	DWG. NO.: P-30

Performance Data

Pressure drop test per AMCA Standard 500-D, Figure 5.3.

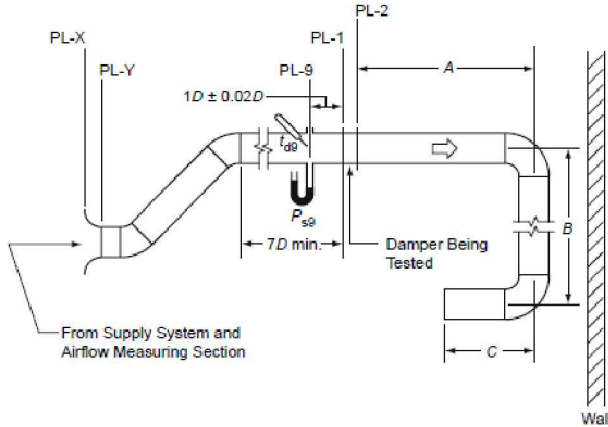

AIR FLOW RESISTANCE

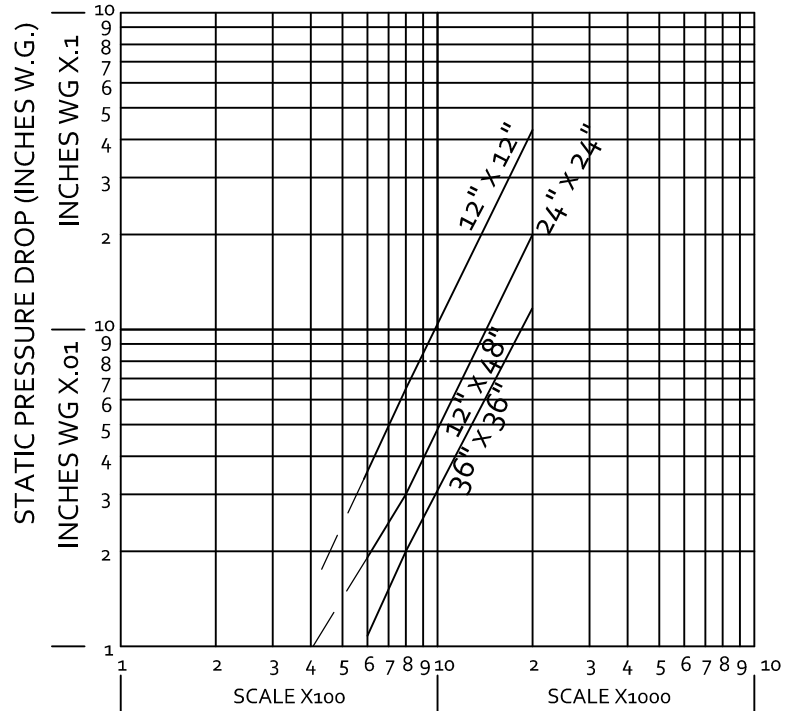

FDD-110-3v sizes: 12" x 12", 24" x 24", 48" x 12", 12" x 48", 36" x 36"
 (305 x 305mm, 610 x 610mm, 1219 x 305mm, 305 x 1219mm, 914 x 914mm)
 Data corrected to standard air density

When the actuator is externally mounted and the wall thickness exceeds 5 inches, add 1 inch for each additional inch of wall thickness increased, to ensure sleeve extends through the penetration. As standard the actuator is externally installed on the lower right hand half of the damper when viewed from the jackshaft side. The damper may be installed or rotated 180° such that the actuator will be located on the upper left. The top of the damper is either side of the frame as long as the blades are running horizontal. When ordering internally mounted actuators, be aware there is a min. height requirement (in some cases the sleeve can be increased to allow for internal mounting). The entire damper frame does not have to be installed in the plane of the wall/floor. The rule of thumb is "with the damper in the closed position, the blade plane should be within the plane of the UL rated wall/floor".

